

Company profile

ALMEVA EAST EUROPE a.s.

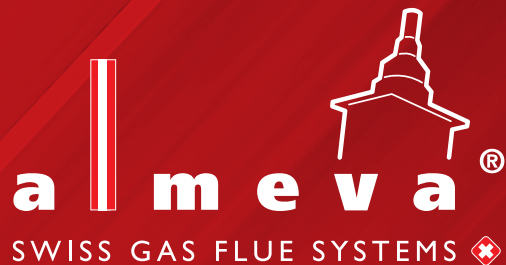

Designed in
Switzerland

+ Since 1994



Professional chimney systems



Company Profile and Vision	4
History	5
Management	6
Services and Solutions	7
Product overview	8
PLASTIC FLUE SYSTEMS	9
Fixed plastic smoke evacuation system STARR	10
Flexible plastic smoke extraction system FLEX	11
Internal concentric air/gasoline system LIK / LIL / LIB	13
Outdoor concentric air/gas system LAB / LAL / LAM / LAC	14
Combustion system for appliances independent of room air combustion LAS	15
Fuel system for appliances in cascade CAS	16
Accessories for chimney systems ZUB	17
ALUMINIUM FLUE SYSTEMS AL1, AL2	18
STAINLESS STEEL FLUE SYSTEMS	19
Single-layer, moisture-resistant stainless steel remediation system EW	20
Three-layer stainless steel system DW25	21
Multilayer concentric system TW25	22
Stainless steel concentric system DK	23
Single-layer stainless steel flexible system INOX FLEX FB	24
Single layer stainless steel flexible system INOX FLEX G	25
Silencers	26
STEEL FLUE SYSTEMS	27
Single-layer steel flue system ORM	28
Single-layer steel system for overpressure (pellet) PL	29
MASONRY FLUE SYSTEMS	30
Three-component masonry chimney system with liner SIB / SIZ / MIB	31
Two-component chimney system with plastic liner KLB / KLZ / ELB / ELZ	32
Three-component chimney system with stainless steel liner EIB / EIZ	33
Single component masonry chimney system SINGLE	34
Chimney system ALMEVA FESTGAS	35
EXHAUST FANS, DRAUGHT BOOSTER, PARTICULATE FILTER, HEAT RECOVERY	36
Exhaust fans Exodraft	37
Thrust booster Draftbooster	38
Particulate filter (electrostatic precipitator) for wood-burning stoves	39
Heat Recovery System	40
FIREPLACE STOVE ALMEVA HEARTH	41
Fireplace stove ALMEVA Hearth	42
ACCESSORIES	43
Cleaning technology	44
ALMEVA shaft system	45
Chimney penetrations through combustible construction KAMINSICHER	46
Chimney drugs	47
Sauna stove Vilpra	48
Computer program kesa-aladin	49
TECHNICAL DEVELOPMENT PRODUCTS	50
Neutralization box Almeva	51
Innovative siphon Almeva ZEUS	52
87° knee for insertion	53
Software from almeva for chimney calculation Almecon	54

MANAGEMENT

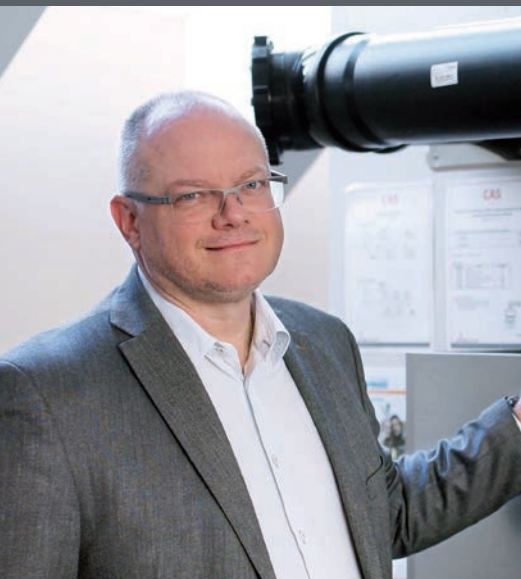

Pavel Mareček

Chairman of the Management Board
CEO of the company



Markéta Budovičová

Member of the Management Board
economist of the company



Pavel Ulrich

Member of the Management Board
Commercial Director of the company

It has been in business since 1993. In 1997 he co-founded TECH TRADING spol. s r. o. as a regional supplier of chimneys. He participated in the creation of the EKO KOMÍN brand and its expansion throughout the Czech Republic and abroad, especially in Eastern Europe. Since 2008 it has been trading its own product EUROKOMÍN. In 2006 he was instrumental in the inclusion of ALMEVA chimneys in the portfolio of TECH TRADING and subsequently co-founded the independent company ALMEVA EAST EUROPE. He is the managing director of ALMEVA POLAND Sp. z o.o., ALMEVA SLOVAKIA s.r.o. and ALMEVA HUNGARY Kft. and a member of the close management of ALMEVA AG in Switzerland. He is a member of the Association of Chimney Sweepers of the Czech Republic and the Chamber of Chimney Sweepers of Slovakia, a member of the Guild of Chimney Sweepers of the Czech Republic, a member of the Guild of Heating Engineers and Plumbers of the Czech Republic, a member of the Technical Standardization Commission 105 Chimneys at the ÚNMZ Prague.

For ten years she worked in the financial controlling department of CIMEX Group companies, responsible for the preparation of the Group's consolidated financial statements. From 2001 to 2008 she served on the Board of Directors of INTERHOTEL VORONĚŽ s.r.o., 1997-2002 as a liquidator of UTI, a joint stock company. She has been working for ALMEVA EAST EUROPE since 2010 as an economist. Since August 2014 as a proxy of the company, after the transformation into a joint stock company, he is a member of the Management Board. Since 2016 he has been a proxy in the Polish subsidiary ALMEVA POLAND.

After graduating from the Faculty of Civil Engineering at the Brno University of Technology, he joined ALMEVA EAST EUROPE in 2011 as a technician and after a year he started working as a production and technical manager. He took care of the transfer of part of the production from Switzerland and headed the technical department, where he set the company standards for the operation of technical consulting and training, which were implemented in the subsidiaries. As of March 2021 he is the company's commercial director, then a proxy and after the change of form to a public limited company a member of the Board of Directors. Member of the Association of Chimney Sweepers of the Czech Republic.

SERVICES AND SOLUTIONS



ALMEVA EAST EUROPE a.s. offers a wide portfolio of products and a number of services related to the provision of professional consulting and after-sales service.

Our product range includes all types of flue systems from plastic, stainless steel, aluminium, steel, flexible to masonry. We keep all systems in stock in sufficient quantities to meet customer requirements. We move predominantly in a B2B environment, therefore our primary customers are companies and tradesmen in the contracting industry. To get a better idea of how to build a chimney, our chimney configurator will help you build a complete smoke extraction system. In the web browser environment you select the necessary elements, the system calculates the price and creates an order. The rest is taken care of by our experienced staff, who will prepare everything for pick-up or send the goods to your address.

We want to be as close to our customers as possible, that's why we cooperate with partners in business networks not only in the Czech Republic, but also in Slovakia, Poland and Hungary. Implementation companies and companies involved in architectural projects will be happy to save time and leave the calculation of the flue gas duct to us. Using the kesa-aladin software, we will prepare your project and recommend a suitable flue gas extraction system. The technical department has several specialists in the field of chimney technology who will help you with the flue calculation and recommend the appropriate material according to the type of appliance.

At Exodraft we offer mechanical chimney draft control technology. Flue fans are becoming an integral part of the chimney where there is a need to control the chimney draft. We offer fans of various capacities

and temperature ranges. In addition to fans, we also offer advanced Heat Recovery System technology, which is a major challenge for plants in times of rising energy prices, where large amounts of waste heat are generated. The recovered heat can be used, for example, to heat buildings or to heat domestic water. In addition to the energy recovered, the resulting CO₂ emissions are also reduced.

PRODUCT OVERVIEW

EXHAUST SYSTEMS



PLASTIC
FLUE GAS SYSTEMS



ALUMINUM
FLUE GAS SYSTEMS



NEREALS
FLUE GAS SYSTEMS



STEEL
FLUE GAS SYSTEMS



BACKGROUND
FLUE GAS SYSTEMS

ACCESSORIES



EXODRAFT
EXHAUST FANS



TRACTION BOOSTER
DRAFT BOOSTER



EXODRAFT
PARTICULATE FILTER



RECOVERY
HEAT



KRB'S STONE
HEARTH



CLEAN
TECHNOLOGY



SHAFT SYSTEM
ALMEVA



CHIMNEY PENETRATIONS
THROUGH COMBUSTIBLE
CONSTRUCTION



CHIMNEYS
DRUGS



SAUNA STONE
VILPRA



COMPUTER PROGRAM
KESA-ALADIN

PRODUCTS OF TECHNICAL DEVELOPMENT



NEUTRALIZATION BOX
ALMEVA



INNOVATIVE SIPHON
ALMEVA ZEUS



KNEE 87°
FOR INSERTION



ALMECON - CUSTOM SOFTWARE
FOR CHIMNEY CALCULATION

PLASTIC FLUE SYSTEMS

The ALMEVA plastic flue gas system is a modern solution for overpressure flue gas extraction from condensing and low-boilers with flue gas temperatures up to 120 °C. At the same time it is designed for the flue gas path from appliances burning gaseous fuels, respectively natural gas (L, H) and liquid fuels (LTO with sulphur content $\leq 0.2\%$, kerosene).

CHARACTERISTICS

- › modern flue gas path for condensing and low-temperature boilers
- › more than 2500 catalogue items
- › material PPH (polypropylene homopolymer)
- › wall thickness from 1 mm to 5.5 mm depending on DN
- › Swiss quality guaranteed
- › for flue gas temperature max. 120 °C
- › condensate resistant pipe
- › for positive pressure and high-pressure operation
- › hassle-free and quick installation
- › for new construction and chimney rehabilitation



ADVANTAGES

MADE IN SWITZERLAND

We manufacture directly in Switzerland, some elements in Germany and the Czech Republic.

MATERIAL

Our basic material is a special cross-linked polypropylene, called PPH. It is resistant to temperatures up to 120 °C and to the acidic condensate that naturally occurs in the flue gas. It has an ideal strength to flexibility ratio.

SEALS

Perfect sealing of the flue system is ensured by four-ribbed rings made of ethylene propylene diene rubber (EPDM). This is a high-quality elastomer with

a long service life and high resistance to condensate, temperature, oxidation and atmospheric influences.

THE WIDEST RANGE OF

The ALMEVA plastic flue system includes a range of sub-systems to address different types of operational requirements inside and outside buildings. We offer customers over 200 components in various dimensions, which are an indispensable part of a functional modern flue. In total, there are more than 2,500 items to choose from.

10 YEAR WARRANTY

A complete flue system installed by an authorised organisation is guaranteed for 10 years.

COMFORT

We develop all elements in close cooperation with experienced experts. This guarantees trouble-free operation, fast installation and increased productivity.

CERTIFICATION

All ALMEVA products comply with CSN/STN EN 14471 + A1, are duly certified and have been assigned the CE marking symbol corresponding to Directive 93/68/EC. The production management system is according to ISO 9001:2015 standards.

FLEXIBLE AND FAST

A large part of the system items are in stock, others we can produce quickly, including atypical solutions for some parts.

FIXED PLASTIC SMOKE EVACUATION SYSTEM

STARR

Single layer plastic STARR smoke extraction system consisting of fixed pipes, fittings and PPH accessories. It is designed especially for interior use and for the insertion of straight chimney flues. The individual elements of the STARR system are connected by socket joints with four-part EPDM seals.

It is used for exhausting flue gases from condensing and low-temperature boilers with a maximum flue gas temperature at the appliance smoke outlet of 120 °C. It is designed mainly for high-pressure and high-pressure flue gas ducts. It can also be used for natural draught chimneys. It is not intended for flue gas ducts where soot can burn off. It is suitable for chimneys that are planned to be operated in wet operation mode and applicable for flue gas flue from appliances burning gaseous fuels or natural gas (L,H) and liquid fuels (LTO with sulphur content up to 0,2 % kerosene)

PARAMETERS

Classification	to EN 14471:2013+A1:2015
Operating temperature	up to 120 °C
Type of operation	condensing boiler
Fuels	liquid and gaseous fuels
Material	PPH
Diameter	60–315 mm

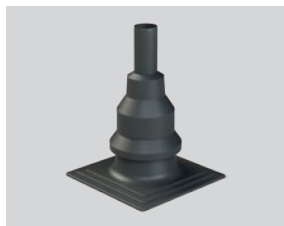

FLEXIBLE PLASTIC SMOKE EVACUATION SYSTEM

FLEX

The FLEX plastic single-layer smoke evacuation system consists of flexible hoses, fittings and accessories. It is especially designed for the insertion of straight and angled chimney flues. The individual elements of the FLEX system are connected by means of bayonet socket joints with a sleeve and an EPDM seal.

The flexible plastic FLEX smoke extraction system is used to extract flue gases from condensing and low temperature boilers with a maximum flue gas temperature of 120 °C at the appliance smoke outlet. It is mainly designed for high-pressure and high-pressure flue gas paths. It can also be used for natural draught chimneys. It is not intended for flue gas ducts where soot can burn off. It is suitable for chimneys that are planned to be operated in wet operation mode and applicable for flue gas from appliances burning gaseous fuels, respectively natural gas (L,H) and liquid fuels (LTO with sulphur content up to 0,2 % kerosene).

PARAMETERS

Classification	according to EN 14471:2013+A1:2015
Operating temperature	up to 120 °C
Type of operation	condensing boiler
Fuels	liquid and gaseous fuels
Material	PPH
Diameter	60–200 mm



The new residue-free flexible ALMEVA Flex system

Suitable for flue gas extraction from condensing and low-temperature boilers, especially for angled chimneys.



FLEXIBLE HOSES

- flue gas extraction from condensing and low-temperature boilers
- ideal for angled chimneys
- diameter 80 mm
- seamless system
- longer service life
- simple and quick installation

FLEX CHIMNEY PACKAGE

- elements for the foundation and termination of the chimney in 1 package
- packages with insert or heel elbow
- choice of standard versus reduced elbow
- at a discounted price
- time saving
- easy installation

ALMEVA FLEXBOX

- 50 metres of flexible hose in one box
- practical opening
- assembly instructions directly on the box
- auxiliary meter and remaining quantity indicator
- flexible hose refill option
- convenient handling



Designed in Switzerland



More than 9,000 chimney elements



3 000 items in stock



Professional technical support



Certificate of Quality of the Hospitality Chamber of the Czech Republic

INTERNAL CONCENTRIC AIR/GASOLINE SYSTEM

LIK / LIL / LIB

The LIK plastic smoke evacuation system consists of concentric fixed pipes and PPH/PPH fittings. The LIL and LIB smoke evacuation system consists of concentric fixed pipes and PPH/ stainless steel high polished or stainless steel white comaxit fittings. They are mainly designed for flue gas ducts in indoor environments. The connection of the individual elements of the system is by socket joints with EPDM seals.

It is used for exhausting flue gases from condensing and low-temperature boilers with a maximum flue gas temperature at the appliance smoke outlet of 120 °C. It is designed mainly for high-pressure and high-pressure flue gas ducts. It can also be used for natural draught chimneys. It is not intended for flue gas ducts where soot can burn off. It is suitable for chimneys which are planned to be operated in wet operation and applicable for flue gas from appliances burning gaseous fuels, or natural gas (L,H) and liquid fuels (LTO with sulphur content up to 0,2 % kerosene).

PARAMETERS

Classification	according to EN 14471:2013+A1:2015
Operating temperature	up to 120 °C
Type of operation	condensing boiler
Fuels	liquid and gaseous fuels
Material	LIK: PPH/PPH LIL: PPH/stainless steel - white comaxite LIB: PPH/stainless steel - highly polished
Diameter	LIK: 60/100 a 80/125 mm LIL: 60/100–200/300 mm LIB: 60/100–200/300 mm



OUTDOOR CONCENTRIC AIR/GAS SYSTEM

LAB / LAL / LAM / LAC

The plastic smoke evacuation system consists of concentric fixed pipes and PPH fittings - high polished stainless steel, stainless steel comaxitated white sheet, matt stainless steel and stainless steel with non-galvanized copper coating. It is especially designed for flue gas ducts in outdoor environments. The connection of the individual elements of the system is by conical joints.

It is used for exhausting flue gases from condensing and low-temperature boilers with a maximum flue gas temperature at the appliance smoke outlet of 120 °C. It is designed mainly for high-pressure and high-pressure flue gas ducts. It can also be used for natural draught chimneys. It is not intended for flue gas ducts where soot can burn off. It is suitable for chimneys that are planned to be operated in wet operation mode and applicable for flue gas from appliances burning gaseous fuels, respectively natural gas (L,H) and liquid fuels (LTO with sulphur content up to 0,2 % kerosene).

PARAMETERS

Classification	according to EN 14471:2013+A1:2015
Operating temperature	up to 120 °C
Type of operation	condensing boiler
Fuels	liquid and gaseous fuels
Material	LAB: PPH/stainless steel - highly polished LAL: PPH/stainless steel - white comaxite LAM: PPH/stainless steel - matt LAC: PPH/stainless steel - electroplated
Diameter	60/100–200/300 mm



COMBUSTION SYSTEM FOR APPLIANCES INDEPENDENT OF ROOM AIR COMBUSTION

LAS

The LAS plastic smoke evacuation system consists of fixed pipes, fittings with 87° branches and accessories PPH, PPH/stainless - highly polished, white comaxite. The system is offered as a single layer in diameters from 60 mm to 315 mm or as concentric in diameters from 60/100 mm to 200/300 mm. It is especially designed for connecting multiple appliances to a common chimney in indoor or outdoor environments.

It is used for exhausting flue gases from condensing and low-temperature boilers with a maximum flue gas temperature at the appliance smoke outlet of 120 °C. Ideal mainly for pressurized and high-pressure flue gas paths. It can also be used for natural draught chimneys. It is not intended for flue gas flues where soot can burn out. It is suitable for chimneys which are planned to be operated in wet operation mode and applicable for the flue gas flue from appliances burning gaseous fuels or natural gas (L,H) and liquid fuels (LTO with sulphur content up to 0,2 %, kerosene, etc.)

PARAMETERS

Classification	according to EN 14471:2013+A1:2015
Operating temperature	up to 120 °C
Type of operation	condensing boiler
Fuels	liquid and gaseous fuels
Material	Option 1: PPH Option 2: PPH/stainless steel - white comaxite Option 3: PPH/stainless steel - highly polished
Diameter	Option 1: 60–315 mm Option 2: 60/100–200/300 mm Option 3: 110/160–200/300 mm



FUEL SYSTEM FOR APPLIANCES IN CASCADE

CAS

The CAS plastic smoke evacuation system consists of fixed pipes, fittings with 45°, 87° branches and PPH accessories. The system is offered as a single layer system in diameters from 80 mm to 315 mm and as a concentric system with a white comaxitized stainless steel casing in diameters from 110/160 mm to 200/300 mm. It is particularly suitable for cascades in indoor environments.

It is used for exhausting flue gases from condensing and low-temperature boilers with a maximum flue gas temperature at the appliance smoke outlet of 120 °C. It is designed mainly for high-pressure and high-pressure flue gas ducts. It can also be used for natural draught chimneys. It is not intended for flue gas ducts where soot can burn off. It is suitable for chimneys which are planned to be operated in wet operation and applicable for flue gas from appliances burning gaseous fuels, or natural gas (L,H) and liquid fuels (LTO with sulphur content up to 0,2 % kerosene).



PARAMETERS

Classification	according to EN 14471:2013+A1:2015
Operating temperature	up to 120 °C
Type of operation	condensing boiler
Fuels	liquid and gaseous fuels
Material:	Option 1: PPH Option 2: PPH/stainless steel - white comaxite
Diameter	Option 1: 80–315 mm Option 2: 110/160–200/300 mm



ACCESSORIES FOR CHIMNEY SYSTEMS

ZUB

The ALMEVA plastic chimney systems also include accessories marked ZUB. The accessories are designed for plastic and aluminium systems where the technical and utility properties of the smoke extraction are increased.

- › Neutralization boxes
- › Siphons
- › Lubricants for easy joining
- › Condensate drainage pump
- › Grommets, sleeves, grilles
- › Replacement seals and caps
- › Anchoring technology

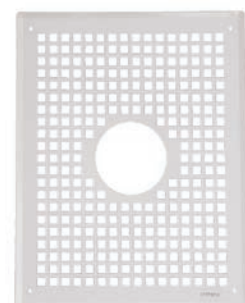

ALUMINIUM FLUE SYSTEMS AL1, AL2

Aluminium smoke extraction systems AL1, AL2 consist of fixed pipes, fittings and accessories. The AL1 system is offered in diameters of 60, 80 and 100 mm in painted or unpainted versions as a single layer. The AL2 system is concentric in 60/100 mm and 80/125 mm diameters with a painted jacket. The systems are mainly intended for interior use and for the insertion of straight chimney flues. The connection of the individual elements is by socket joints with three-edged seals.

It is used for exhausting flue gases from TURBO appliances or hot air units with the highest flue gas temperature at the appliance's smoke outlet of 200 °C. It is designed mainly for pressurised flue gas ducts. It can also be used for natural draught chimneys. It is not intended for flue gas ducts where soot can burn off. It is suitable for chimneys that are planned to be operated in wet operation.

PARAMETERS

Classification	according to EN 14471:2013+A1:2015
Operating temperature	up to 200 °C
Type of operation	turbo boiler, hot air unit
Fuels	liquid and gaseous fuels
Material	AL1: aluminium AL2: aluminium/aluminium, steel - white comaxite
Diameter	AL1: 60–100 mm AL2: 60/100 a 80/125 mm

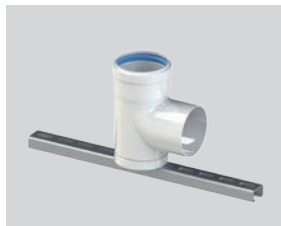

STAINLESS STEEL FLUE SYSTEMS

The ALMEVA stainless steel flue system is a universal modern solution for flue gas extraction from all types of appliances. It is suitable for use in both pressurised flue gas ducts and natural draught chimneys. The resistance of the material suits both wet and dry operation.

CHARACTERISTICS

- › universal flue gas path for all types of solid, liquid and gaseous fuel appliances
- › more than 1,700 catalogue items
- › material: stainless steel
- › high quality
- › condensate resistant pipe
- › for pressurised operation (when using seals) also for natural draft operation
- › smooth and quick installation
- › for new construction and rehabilitation (reconstruction)



ADVANTAGES

MATERIAL

For the production of our stainless steel flue systems, we use stainless steel sheet made from the highest quality grade 1.4404 stainless steel.

SEALS

The tightness of the flue system is ensured by silicone or EPDM gaskets with instant excellent tightness with long lasting joint flexibility. This type of gasket speeds up and simplifies system assembly.

MADE IN EUROPE

All elements are manufactured in European Union countries using first-class materials.

A COMPLETE SYSTEM

The ALMEVA stainless steel flue system includes a number of components. It contains more than 200 elements in various dimensions that are an indispensable part of a functional modern flue. In total, there are more than 1,700 items to choose from.

FLEXIBILITY AND SPEED

We have a large number of system items in stock. Other items can be delivered quickly.

QUALITY AND PRECISION

Through a time-tested and constantly innovated process, we have achieved perfect precision and quality in all pipes, fittings and other accessories. The result is a precisely designed throat joint shape, perfect flue gas flow and low risk of fouling.

SINGLE-LAYER, MOISTURE-RESISTANT STAINLESS STEEL REMEDIATION SYSTEM

EW

The stainless steel sanitary chimney system Almeva EW is suitable for exhausting flue gases from all types of solid, liquid and gaseous fuel appliances operating in vacuum operation (with natural draught) and, with the use of seals, also in positive pressure operation. It is made of stainless steel grade 1.4404. The system is moisture resistant and allows both dry and wet operation.

The wide range of elements allows for virtually any type of flue gas extraction. The entire flue (chimney and flue) can be assembled from this system. The system can be combined with flexible systems. The advantage of the system is the bayonet neck connection technique ($DN \leq 200$ mm), which guarantees the system's tightness against flue gas leakage and condensate, without the use of additional clips or riveting.

PARAMETERS

Classification	according to EN 1856-2:2009
Operating temperature	up to 600 °C
Type of operation	all types of appliances
Fuels	all fuel types
Material	stainless steel, wall 0,5–0,8 mm
Diameter	80–600 mm

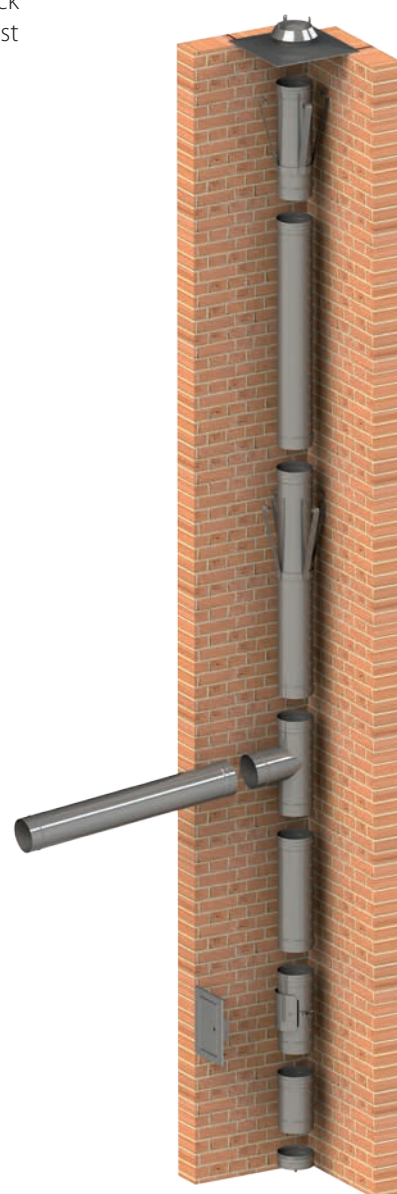
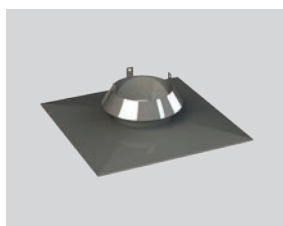

THREE-LAYER STAINLESS STEEL SYSTEM

DW25

The universal three-layer stainless steel chimney system Almeva Triple DW25 is suitable for all types of fuels and all types of appliances that operate in both vacuum and pressurized operation. The range of applications is wide - from conventional heat and condensing appliances, to boiler houses, generators, block boilers, emergency units and furnaces.

High-quality stainless steel grade 1.4404 and a high-quality technical solution also allow wet operation - the system is resistant to moisture. The system allows easy transition to single-skin systems. Its composition makes it suitable for internal and external installation as well as for stand-alone chimneys.

PARAMETERS

Classification	according to EN 1856-1:2009
Operating temperature	up to 600 °C
Type of operation	all types of appliances
Fuels	all fuel types
Material	stainless steel/insulation/stainless steel
Diameter	80-550 mm

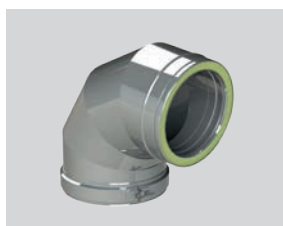
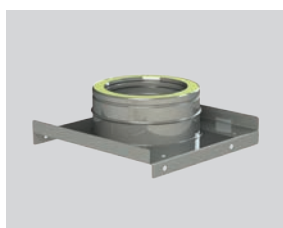
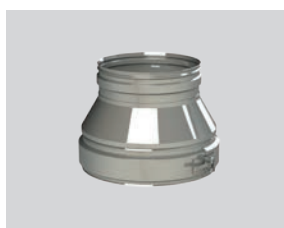

MULTILAYER CONCENTRIC SYSTEM

TW25

Acid-resistant steel concentric system ALMEVA Quadra TW25. Moisture-resistant, multilayer concentric system for vacuum operation, for solid fuel appliances independent of room air intake.

The ALMEVA Quadra TW25 acid-resistant steel chimney system is suitable for solid fuel appliances operating in vacuum mode. It is designed for appliances that are connected to an external combustion air supply for combustion. The system is widely used in low energy houses and passive houses. It is also suitable for installation in older buildings with increased air supply requirements.

PARAMETERS

Classification	according to EN 1856-1:2009
Operating temperature	up to 450 °C
Type of operation	solid fuel appliances
Fuels	solid fuels
Material	stainless steel/insulation/stainless steel/painted stainless steel
Diameter	150-250 mm



STAINLESS STEEL CONCENTRIC SYSTEM

DK

Concentric stainless steel flue system ALMEVA Double DK made of acid and moisture resistant steel. It is designed for pressurised operation.

The ALMEVA Double DK stainless steel concentric system is suitable for exhausting flue gases from gas and oil appliances independent of room air, operating in pressurised mode and is designed for wet operation. It is made of stainless steel grade 1.4404/316L. Its advantage is the easy and quick assembly by connecting the individual elements with a gasket that secures the connection.

PARAMETERS

Classification	according to EN 14989-2
Operating temperature	up to 200 °C
Type of operation	gas and liquid fuel appliances
Fuels	liquid and gaseous fuels
Material	stainless steel/stainless steel
Diameter	80/125–400/600 mm

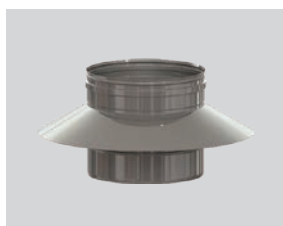
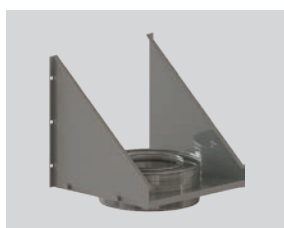

SINGLE-LAYER STAINLESS STEEL FLEXIBLE SYSTEM

INOX FLEX FB

Flexible stainless steel chimney system designed for the insertion of angled chimney flues with a wall thickness of 0.4 mm.

Stainless steel flexible chimney system Almeva INOX FLEX FB is suitable for exhausting flue gases from all types of solid fuel appliances operating in vacuum mode (with natural draft) and is designed for dry operation. It is made of stainless steel grade 1.4404 / 316L.

PARAMETERS

Classification	according to EN 1856-2:2009
Operating temperature	up to 450 °C
Type of operation	solid fuel appliances
Fuels	solid fuels
Material	stainless steel
Diameter	120–200 mm

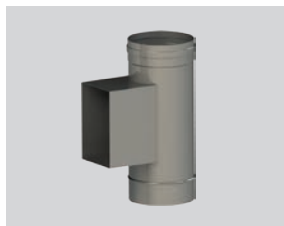

SINGLE-LAYER STAINLESS STEEL FLEXIBLE SYSTEM

INOX FLEX G

Flexible stainless steel chimney system designed for the insertion of angled chimney flues with a wall thickness of 0.1 mm.

The stainless steel flexible chimney system ALMEVA INOX FLEX G is suitable for exhausting flue gases from all types of appliances burning gaseous fuels, operating in both vacuum and overpressure mode. The system is designed for both wet and dry operation and is made of stainless steel grade 1.4404.

PARAMETERS

Classification	according to EN 1856-1:2009
Operating temperature	up to 450 °C, with sealing to 200 °C
Druh provozu	gas and liquid fuel appliances
Fuels	liquid and gaseous fuels
Material	stainless steel
Diameter	80–300 mm

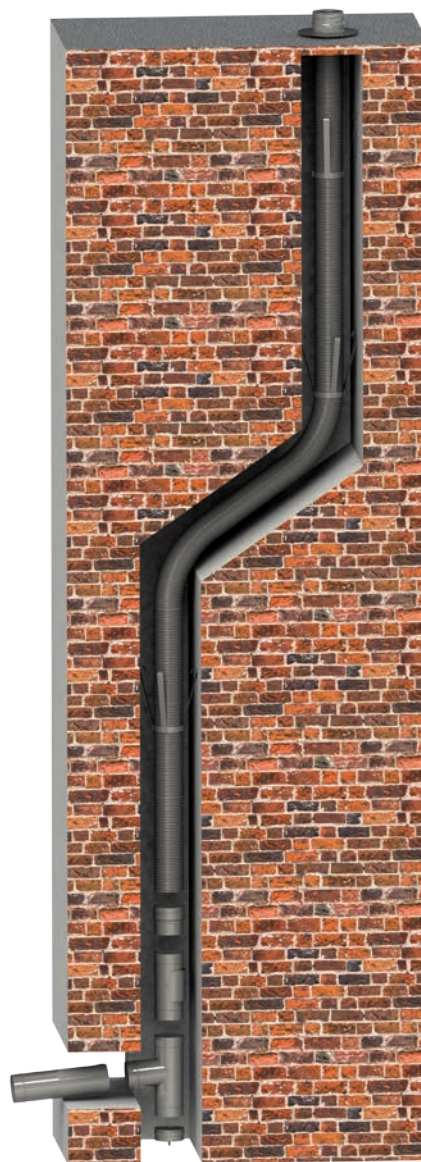
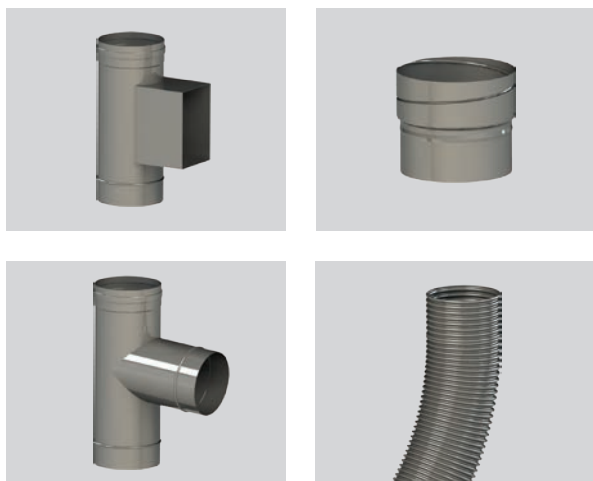

SILENCERS

ALMEVA ASD absorption silencers are used to effectively reduce noise emissions from appliances. These silencers are compatible with the ALMEVA EW stainless steel flue gas extraction system in dimensions from 80 to 500 mm. ALMEVA ASD absorption silencers are available in overall lengths from 700 to 2200 mm.

ALMEVA ASD absorption silencers are suitable for reducing the sound level for gas and oil appliances. The silencers can be used in negative pressure operation (with natural draft), and also in positive pressure operation when seals are used. The high quality stainless steel grade 1.4404 and the technical design allows both dry and wet operation. On request, the damper can be equipped with a condensate drain in the outer jacket (depending on installation).

The acoustic parameters of the silencers were designed in cooperation with the Fraunhofer Institute in Germany. Incidentally, this institute invented the well-known mp3 music format.



STEEL FLUE SYSTEMS

ALMEVA steel flue systems are a universal modern solution for flue gas extraction from all types of solid fuel appliances. It is suitable for use in both pressurised flue gas ducts and natural draught chimneys. The resistance of the material suits both wet and dry operation.

CHARACTERISTICS

- › universal flue gas path for all types of solid fuel appliances
- › more than 30 elements
- › material: steel
- › high quality
- › condensate resistant pipe
- › for pressurised operation (when using seals) also for natural draft operation
- › smooth and quick installation
- › for new construction and rehabilitation (reconstruction)



ADVANTAGES

MATERIAL

We use S235JRG2 grade steel of the highest quality for the production of steel flue systems.

SEALS

The tightness of the flue gas system is ensured by a silicone seal with long-term elasticity of the joint. This type of gasket speeds up and simplifies the assembly of the system.

MADE IN EUROPE

All elements are manufactured in Europe from first-class materials. No component has a non-European origin.

A COMPLETE SYSTEM

The ALMEVA all-steel flue system includes a variety of components. It contains more than 30 elements in various dimensions that are an indispensable part of a functional modern flue. In total, there are more than 120 items to choose from.

FLEXIBILITY AND SPEED

Apart from the reducers, all items are in stock. We can deliver the other items quickly.

QUALITY AND PRECISION

Through a time-tested and continuously innovated process, we have achieved perfect precision and quality in all our pipes, fittings and all other accessories. The result is a precisely designed throat joint shape, perfect flue gas flow and low risk of fouling.

SINGLE-LAYER STEEL FLUE SYSTEM

ORM

The black-painted steel flue system, or black flue, is designed primarily for the connection of solid fuel appliances.

The ALMEVA Easy ORM steel solid chimney system is suitable for exhausting flue gases from all types of solid fuel appliances operating in vacuum mode (with natural draft) and is designed for dry operation. It is made of steel of class EN 10025-5/S 235 JRG 2.

PARAMETERS

Classification	according to EN 1856-2:2009
Operating temperature	up to 400 °C
Type of operation	all types of solid fuel appliances
Fuels	solid fuels
Material	steel
Diameter	120-200 mm



SINGLE LAYER STEEL SYSTEM FOR OVERPRESSURE (PELLETS)

PL

Single-layer steel system for connecting pellet appliances. The throat joint with a three-pronged silicone gasket ensures a perfect seal.

The ALMEVA Easy PL steel fixed flue system is suitable for flue gas extraction from pellet appliances operating in pressurised mode. It is made of steel of EN 10025-5/S 235 JRG 2.

PARAMETERS

Classification	according to EN 1856-2:2009
Operating temperature	up to 200 °C
Type of operation	solid fuel appliances
Fuels	solid fuels - pellets
Material	steel
Diameter	80 a 100 mm



MASONRY FLUE SYSTEMS

ALMEVA masonry flue systems are a system solution for flue gas extraction suitable for all types of buildings, for all types of appliances and fuels. These systems are known on the Central European market as EUROKOMÍN. In 2018, we took advantage of the synergies in this sector and merged the brands.

THREE-COMPONENT MASONRY CHIMNEY SYSTEMS SIB, SIZ, MIB

- › for all fuels and all types of buildings
- › composed of clay or brick block, thermal insulation and ceramic liner
- › the blocks are provided with holes in the corners for reinforcing the entire chimney body
- › simple and quick assembly

SINGLE COMPONENT BRICK CHIMNEY SYSTEM SINGLE

- › for solid fuels
- › for all types of buildings
- › made of special lightweight block gas-tight expanded clay concrete
- › easy installation with tongue-and-groove system

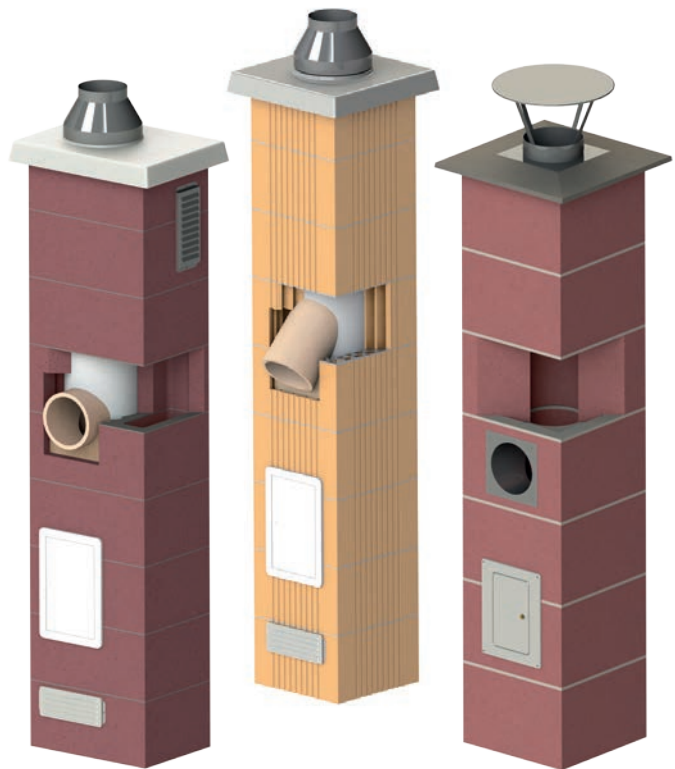

ADVANTAGES

30-YEAR WARRANTY

The complete SIZ, SIB and MIB masonry flue system, installed exactly according to the instructions, is guaranteed for 30 years.

COMFORT

We develop all elements in close cooperation with experienced experts. This guarantees trouble-free operation, fast installation and increased productivity.

FLEXIBILITY AND SPEED

We have all system items in stock for you.

CERTIFICATION

In addition to the usual tests and certifications, in February 2019 we successfully passed the chimney fire resistance test of at least 90 minutes according to the German standard DIN 18160-60. Only a few manufacturers in Europe have this test.

THREE-COMPONENT MASONRY CHIMNEY SYSTEM WITH LINER

SIB / SIZ / MIB

Three-component chimney system of the highest quality, consisting of block, thermal insulation and ceramic fireclay liner designed for all types of fuels and for all types of buildings.

The space between the block and the liner is ventilated along its entire length by so-called rear ventilation. The blocks are provided with holes in the corners for reinforcing the entire chimney body and are bonded with a construction adhesive that allows a conventional chimney to be built in one day. The fireclay liners are bonded with a special sealant, bonding the liners on a chemical basis. Almeva masonry chimney systems offer external cladding in a variety of materials. Almeva SIB is made up of clay concrete block and Almeva SIZ is made up of calibrated brick block.

The Almeva MIB system is fitted with a special Multikeram liner without the need for rear ventilation and can be used in low-energy and passive houses.

PARAMETERS

Classification	EN 13063-1, 2 a 3
Operating temperature	up to 600 °C
Type of operation	all types of appliances except condensing appliances
Fuels	solid, liquid and gaseous
Material	SIB, MIB: fireclay/insulation/ceramic concrete block SIZ: fireclay/insulation/brick block
Diameter	140–200 mm

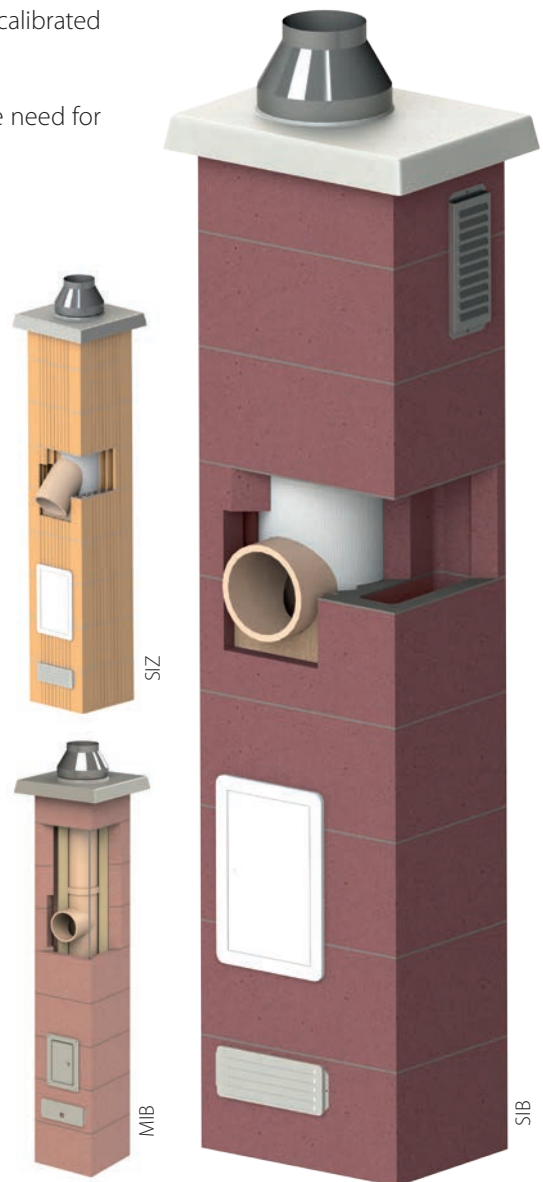

TWO-COMPONENT CHIMNEY SYSTEM WITH PLASTIC LINER KLB / KLZ / ELB / ELZ

It is used for exhausting flue gases from gas and condensing boilers with a maximum flue gas temperature at the appliance throat of 120 °C or 200 °C. It is designed for negative pressure as well as positive pressure flue gas ducts. It is suitable as a common chimney for multiple gas appliance connections on multiple floors. It functions as a concentric flue system for type C appliances.

The advantage is the outer concrete or brick block, which can be declared EI fire resistant, so there is no need for additional cladding, as in systems that do not have an outer cladding consisting of a silicate system. It can be combined in a two-pass block with SIB and SIZ systems. The chimney flue can be assembled during the rough construction, the actual plastic or stainless steel liner is usually fitted when the boiler is installed. The space between the block and the flue pipe itself can be used for independent air supply to the appliance. Very good resistance to acid condensate and long life of the liner.

PARAMETERS

Classification	according to EN 14471:2013+A1:2015 and EN 1856-2
Operating temperature	up to 120 °C and 200 °C
Type of operation	condensing boiler, gas boiler
Fuels	solid, liquid and gaseous fuels
Material	PPH or stainless steel
Diameter	60–250 mm

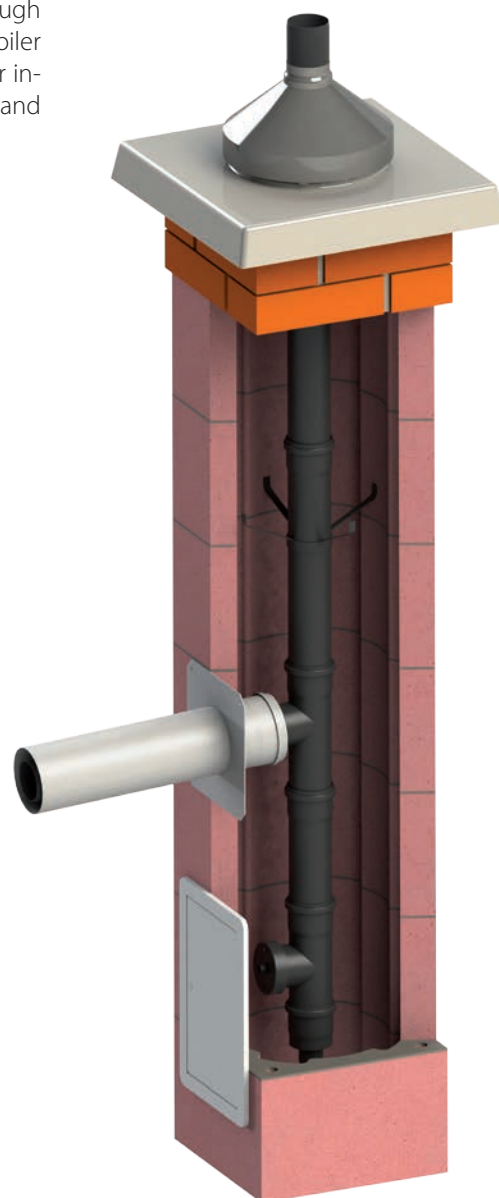
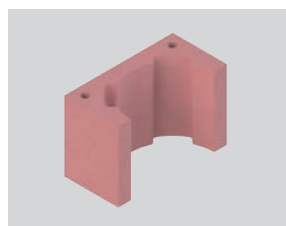

THREE-COMPONENT CHIMNEY SYSTEM WITH STAINLESS STEEL LINER

EIB / EIZ

The EIB and EIZ three-component chimney systems are used for flue gas extraction from gas, liquid and solid fuel appliances. It can be used in negative pressure as well as positive pressure mode. Its primary use is in the construction of new houses.

The advantage of the system is the use of stainless steel chimney liners, which quickly enter the operating mode, reducing the time before the chimney heats up and the chimney draft starts to work properly. Stainless steel liners also eliminate the risk of cracking, as can be the case with ceramic liners. External blocks of lightweight concrete or brick blocks guarantee the excellent fire protection properties of this chimney system.

PARAMETERS

Classification	according to EN 1856-2:2009
Operating temperature	up to 600 °C
Type of operation	all types of appliances
Fuels	all types of fuel
Material	EIB: stainless steel/insulation/ceramic concrete block EIZ: stainless steel/insulation/brick block
Diameter	150-230 mm

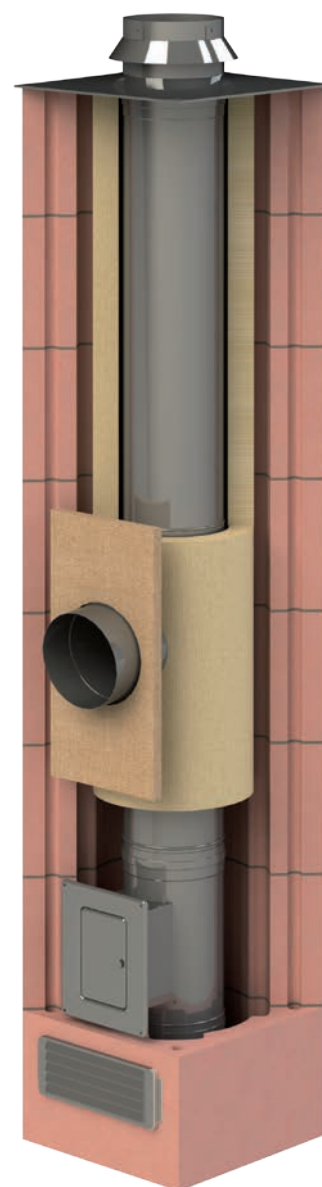
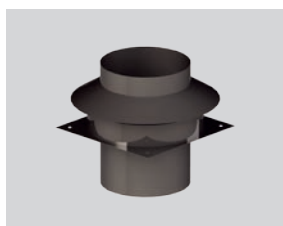

SINGLE COMPONENT MASONRY CHIMNEY SYSTEM

SINGLE

Suitable for all types of buildings (family houses, apartment buildings, holiday homes, administrative buildings, industry, etc.) Designed for solid fuels (especially for fireplaces and stoves without a heat exchanger). Not suitable for solid fuel appliances with low flue gas temperatures with risk of tarring - gasifiers, hot water fireplace inserts, etc. Maximum flue gas temperature in dry operation 400 °C (without soot burn-out resistance).

It is a one-component chimney system of the highest quality, consisting of a special block made of lightweight gas-tight expanded clay. The blocks are bonded with a special gas-tight refractory and quick-setting sealant.

PARAMETERS

Classification	according to EN 1858:2008+A1:2011
Operating temperature	up to 400 °C
Type of operation	solid fuel appliances
Fuels	solid fuels
Material	gas-tight ceramic concrete block
Diameter	180 mm

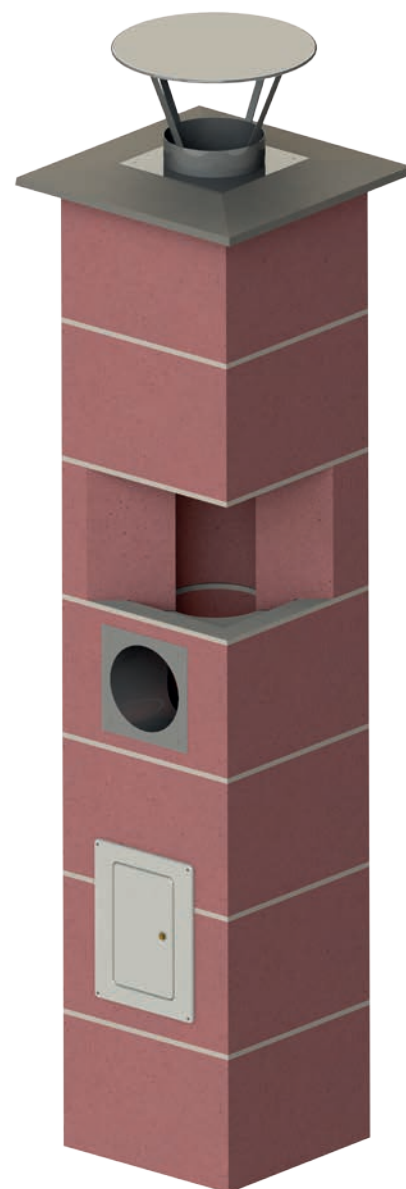
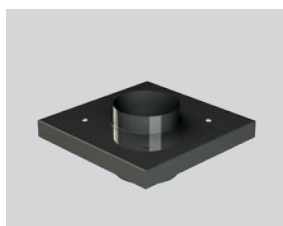
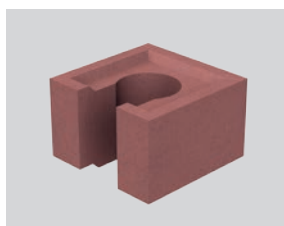

CHIMNEY SYSTEM

ALMEVA FESTGAS

This combined system allows the flue gases from appliances to be exhausted together in one chimney stack gas and solid fuel appliances, including the wiring of other installations. The supporting element of the ALMEVA FESTGAS chimney system is a clay concrete block with one or two vents and two shafts.

In the vent, a ceramic liner wrapped with lamellar insulation leads. The flue gases are diverted from solid fuel appliances via this flue. The ceramic liner can be in diameters of 140, 160, 180 and 200 mm.

A pipe made of high-quality PPH (polypropylene homopolymer) then runs in one ventilation shaft. The flue gases from the condensing boilers are discharged through this pipe. The plastic pipe for the ALMEVA FESTGAS chimney system is supplied in a diameter of 80 mm. The space between the wall of the block and the plastic liner is used to draw in combustion air.

The second ventilation shaft can be used, for example, for cable routing, solar system connection, ventilation of bathrooms, toilets, etc.

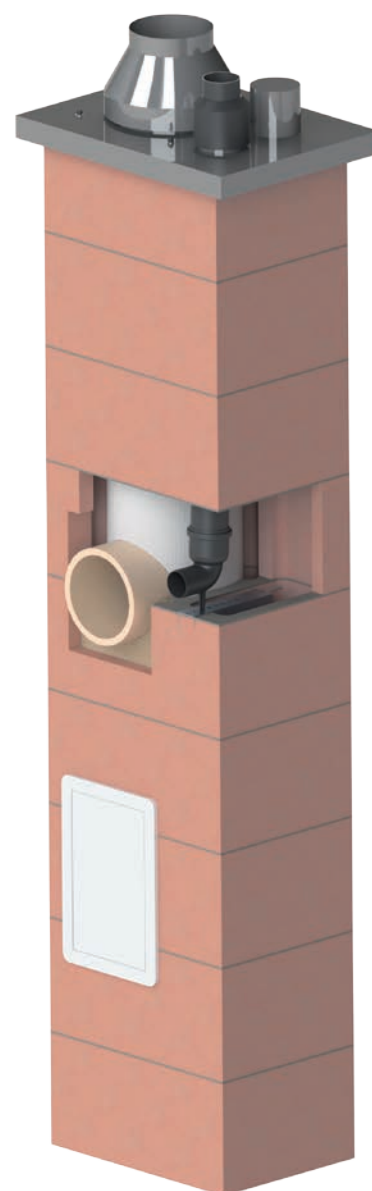

PARAMETERS

Classification	according to EN 14471:2013+A1 and EN13063 - 1,2,3
Operating temperature	up to 120 °C and 600 °C
Type of operation	all types of appliances
Fuels	solid, liquid and gaseous fuels
Material	ceramics, plastic
Diameter	Ceramics: 140–200 mm Plastic: 80 mm

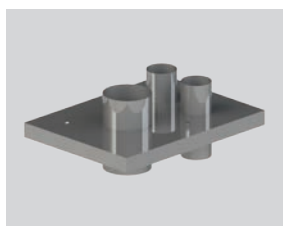
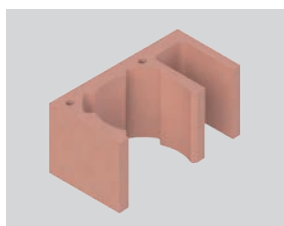

EXHAUST FANS DRAUGHT BOOSTER PARTICULATE FILTER HEAT RECOVERY

The Danish company Exodraft is the market leader in mechanical chimney draft control technology. Exodraft's mechanical chimney draft control systems are based on advanced technology with a focus on simple and safe operation. These features ensure an efficient and reliable chimney draft solution. The company also offers many other technological solutions that are currently relevant with regard to energy saving and environmental impact.

EXHAUST FANS

Ensure you get the right chimney draft with an Exodraft fan. It is important to select a fan according to the type of application, for example for gas boilers, gas fires or fans for solid fuel appliances. A flue fan will ensure a smooth chimney draft and flue gas extraction. The fan also has a positive effect on the amount of fuel consumed.

DRAUGHT BOOSTER

The draft booster device is a modern solution that will solve your stove heating problem. Thanks to the draft booster, you will not find yourself in trouble when the lower temperature in the chimney does not allow a proper draft and your house or favourite holiday cottage will not be full of harmful smoke.

PARTICULATE FILTER

The particulate filter, as the name suggests, is designed to trap fine particles that become electrostatically trapped in the appliance's equipment and thus reduces emissions from wood burning appliances. The advantage of the filter is its self-cleaning function and the function of the built-in chimney fan, which allows for a better chimney draft.

HEAT RECOVERY SYSTEM

If ever increasing energy costs and stringent CO₂ emission requirements are keeping you awake, trust this system to recover waste heat from the operation of the equipment or technology that produces this heat. With a solution from Exodraft, you can use the waste heat for heating water or heating buildings, for example. Investing in a heat recovery plant pays off in terms of financial return, which on average is within three years of commissioning.

Exodraft is the market leader in mechanical chimney draft control technology. Over the last few years we have honed our knowledge and expertise to find solutions for a wide range of tasks in this specific industry. Exodraft mechanical chimney draft control systems are based on advanced technologies with a focus on simple and safe operation. These features will provide you with an efficient and reliable chimney draft solution.

WHAT TYPE AND SIZE OF CHIMNEY FAN TO USE?

It is important to choose both the right type of fan as well as the appropriate accessories.

A chimney fan assembly includes the following parts:

- › Chimney fan
- › Controller (designed for the exact type and operation of the fan)
- › System switch
- › Flange for stainless steel chimneys (if required)
- › Accessories (if required)



OUR RECOMMENDATIONS

Fans for gas boilers

Fans RSV160 to RSV450 or RS285 are commonly used for gas boilers. Depending on the fuel type, RS009 to RS016 or RSV009 to RSV016 can also be used. For cascade connection, an EBC22 or EBC24 automatic control with accessories (if required) must be used. This control is also recommended for single boiler systems.

Fans for gas fireplaces

Five types can be used here: the RHG, RSHG, RSG, RSVG and RHGC. All of these fans are equipped with a draught measurement system which, together with the EFC21 and EBC22 control, will ensure that the gas supply is interrupted if the flue draught falls below the set point to the appliance. Our EFC21 and EBC22 controls are CE certified.

Fans for solid fuel appliances

The RS and RSV types, sizes 009-016, are suitable for these appliances. Type RS has a horizontal exhaust, type RSV a vertical exhaust. Both types have a rotor with axial blades to facilitate soot removal. The RS type is supplied on a square base as standard, but we can also supply an octagonal base on request. Controls are also available with varying degrees of automation, from manual EFC16 and EFC35 to fully automatic units such as the EFC18 and XZENSE.

For a chimney terminating above the roof ridge, both RS and RSV types can be used. RSV vertical exhaust fans are recommended for installations where high airflow is expected, for chimneys terminating below the roof ridge or located on a roof made of combustible material.

THRUST BOOSTER DRAFTBOOSTER



Problems with flooding are usually caused by insufficient chimney draught. The Draftbooster provides the necessary draft and makes it easier to fire up your stove. The draft in the chimney is created by the temperature difference between the higher flue gas temperature and the lower ambient temperature. Since the chimney is always cool when the stove is heated, the draft in the chimney is not always sufficient and room smoking can occur. It is important that the wood is always dry and that small pieces of wood and chips are added to start with. This way the fire will start more quickly and the air needed to create sufficient draft in the chimney will warm up in less time.

FACTS ABOUT DRAFTBOOSTER

When to use Draftbooster?

If you're having trouble getting your wood stove to start, smoke is leaking into the room, or the glass on your stove is dirty from soot, then there is insufficient draft in your chimney and the Draftbooster is an effective solution.

Where can you place a Draftbooster?

The Draftbooster can be placed on any chimney with insufficient draft - on stainless steel or masonry chimneys with a maximum diameter of 220 mm.

What types of appliances can it be used on?

The Draftbooster can be installed when using a sealed wood burning stove or fireplace insert with a rated output from 3 to 8 kW.

How is the Draftbooster connected and how is it operated?

The Draftbooster plugs into a standard wall outlet and is started using the included remote control.

BENEFITS OF USING DRAFTBOOSTER

Ease of firewood ignition and feeding

With the Draftbooster, lighting the wood stove is easy and adding wood is no problem.

Smokeless operation

The Draftbooster exhausts smoke up the chimney to the outside, minimizing soot and smoke entering the room.

Better combustion

Draftbooster ensures better and cleaner combustion.

Faster ignition

The Draftbooster speeds up the ignition process and thus heats the room faster.

Plug and Play

You can easily install the Draftbooster yourself. It is the first fan of its kind in the world.



PARTICULATE FILTER

(ELECTROSTATIC PRECIPITATOR) FOR WOOD-BURNING STOVES

exodraft

The Exodraft ESP-10 is an electrostatic precipitator with a built-in chimney fan for mounting at the chimney mouth. It features a self-cleaning function (patent pending) and is designed to reduce emissions from wood burning appliances and facilitate ignition and refueling. It is designed for closed wood burning fireplaces (stoves) with a rated heat output of 10 kW or less.

The Exodraft ESP-10 particulate filter reduces the number of fine and ultra-fine particles in the exhaust stream by creating an electrostatic field between the charging and collecting electrodes by up to 95%, thus helping to meet environmental standards (e.g. German BImSchV).

The electrostatic field in the device is generated by a charging electrode connected to a high voltage generator that ionises the gas in its surroundings and consequently charges the particles and generates an electrostatic field strong enough to push the charged particles towards the collection electrode. With the electrostatic field on, the precipitated particles remain attached to the collection electrode.

When the temperature and oxygen inside the filter are at a certain level, most of the attached particles will ignite and burn themselves out during complete combustion in normal operation.



HEAT RECOVERY

HEAT RECOVERY SYSTEM

In a market with ever-increasing energy prices and stricter requirements for CO₂ emissions, it is important for us to look for opportunities and place emphasis on the use of energy from flue gases, steam and other processes that are generated during combustion. We therefore consider heat recovery to be economically advantageous in terms of saving and utilising energy from heat generating processes that would otherwise escape through the flue and chimney into the atmosphere. The recovered heat can be used in production plants for heating buildings, heating domestic water or for other purposes.

Reducing fuel consumption

Energy loss from flue gas or other thermal processes is typically around 15-20%. With an exodraft heat recovery system, up to 90% of the heat can be recovered. In other words, there is the potential to reduce fuel consumption by up to 12-18% and a reduction in CO₂ emissions. Exodraft's solution offers efficient heat recovery combined with competitive pricing and a quick return on your investment.

Tailor-made calculations

With exodraft OptiCalc HR™ we are able to offer customers a specific calculation of how much energy their company can save by investing in a heat recovery system. The OptiCalc HR™ simulation software also provides information on the reduction in CO₂ emissions as a result of implementing a heat recovery system.

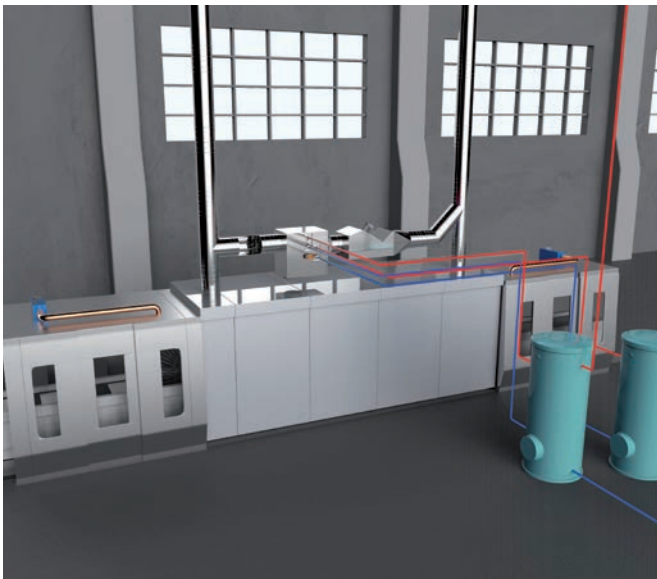

FIREPLACE STOVE

ALMEVA HEARTH



The ALMEVA Hearth fireplace stove offers a unique solution in conjunction with the ALMEVA Quadra TW25 flue system. This connection allows combustion air to be fed through the chimney directly into the stove firebox. Thanks to this unique system, the stove is suitable for passive and low-energy houses with recuperation installed, or for renovations without the need to intervene in the building structure and to build complicated pipes for combustion air supply. Selected stove types are factory-prepared for concentric connection.

ADVANTAGES OF THE SYSTEM

- › Independent air supply through the chimney to the ALMEVA Hearth stove
- › Suitable solution for renovations, low-energy and passive buildings
- › Installation without significant structural intervention
- › The stove is factory-prepared for concentric connection
- › Complete ALMEVA solution - appliance, chimney and installation

THE DETAILS MATTER

The stove is equipped with a variety of practical and design features:

- › The Airbox has been designed to allow a single lever to control primary, secondary and tertiary air supply. The system has been carefully designed and tested over a long period of time to meet all operating conditions.
- › Automatic door closing. Even if you forget to close the stove door, it closes automatically, preventing a possible fire from flying sparks.
- › The SCINTILLA GLASS model is equipped with a practical pull-out drawer for storing stove accessories. In the other models there is a separate practical compartment at the bottom of the stove.

If you decide on a different type of connection, the stove is factory-prepared for top or rear chimney connection. There are three options for independent air supply: concentric, bottom and rear.

We use well-dried and stored wood as fuel for the stove.



FIREPLACE STOVE

ALMEVA HEARTH

The ALMEVA Hearth fireplace stove is a combination of perfect design, a timeless element for the interior and offers high comfort, reliability and elegance. The new range includes 14 types of fireplaces, selected of which have concentric connections.



Scintilla glass*



Foco*



Cubus*



Carbonis



Clara



Angullus



Ardere



* The selected HEARTH stove is ready for connection to the **Almeva Quadra TW25** multilayer chimney, which not only solves the flue gas extraction, but also the air supply.

ACCESSORIES

In the range of accessories we offer systems for flue maintenance, such as mechanical and chemical flue cleaning. Among the accessories we also include the Almeva shaft system, which responds to modern trends in the flue gas extraction industry. The simple certified system allows easy replacement and maintenance of the chimney liner. We also present a chimney guidance system for fire-safety sections under the KAMINSICHER label. This comprehensive system allows individual solutions for a specific building or chimney.



CLEANING TECHNOLOGY

The cleaning technology serves as a supplement for the maintenance and cleaning of flue gas ducts. Mechanical or chemical elements can be used for cleaning depending on the type of flue.

MECHANICAL CLEANING OF FLUE GAS DUCTS

We offer tools such as chimney brushes and suns for mechanical flue cleaning. For easy cleaning of flue pipes, the range of brushes is supplemented by reels, spirals, cleaning rods, ropes and related accessories.

BENEFITS

- › increased appliance performance
- › optimisation of fuel consumption
- › personal safety
- › trouble-free flue gas extraction
- › reduced risk of fire

CHEMICAL FLUE CLEANING

Cre-Away - a tar remover for stoves, boilers, flues and chimneys - is activated by heat. Once activated, it chemically removes tar deposits from appliances, flues and chimneys. Eliminates odours and fire hazards. It can also be used as a preventive measure.

BENEFITS

- › elimination of odours
- › fire prevention
- › easy to use



ALMEVA SHAFT SYSTEM

The ALMEVA shaft system is a modern solution for flue gas extraction, combining ecological materials with the latest trends in flue gas ducts. The system is designed to meet stringent building engineering requirements.

CHARACTERISTICS

- › certified system according to EN 1856-1 or EN14471
- › possibility to replace the chimney liner
- › the system is intended for indoor use only and must be protected against the weather
- › lightweight and compact system for fast construction
- › maximum height of the structure without the riser is 30 metres
- › internal shaft dimensions from 120 mm to 360 mm allow the connection of a wide range of appliances

ADVANTAGES

- › fire resistance 90 minutes (EI90)
- › easy installation
- › environmentally friendly
- › health protection
- › possibility to replace the flue liner
- › the system can be installed vertically with the possibility of bending using elbows

BASIC SYSTEM BREAKDOWN

ALMEVA DOUBLE ELS

Double-layer chimney system with steel liner for appliances with a flue gas temperature of up to 200°C.

ALMEVA DOUBLE KLS

Double layer chimney system with plastic liner for appliances with flue gas temperatures up to 120° C.

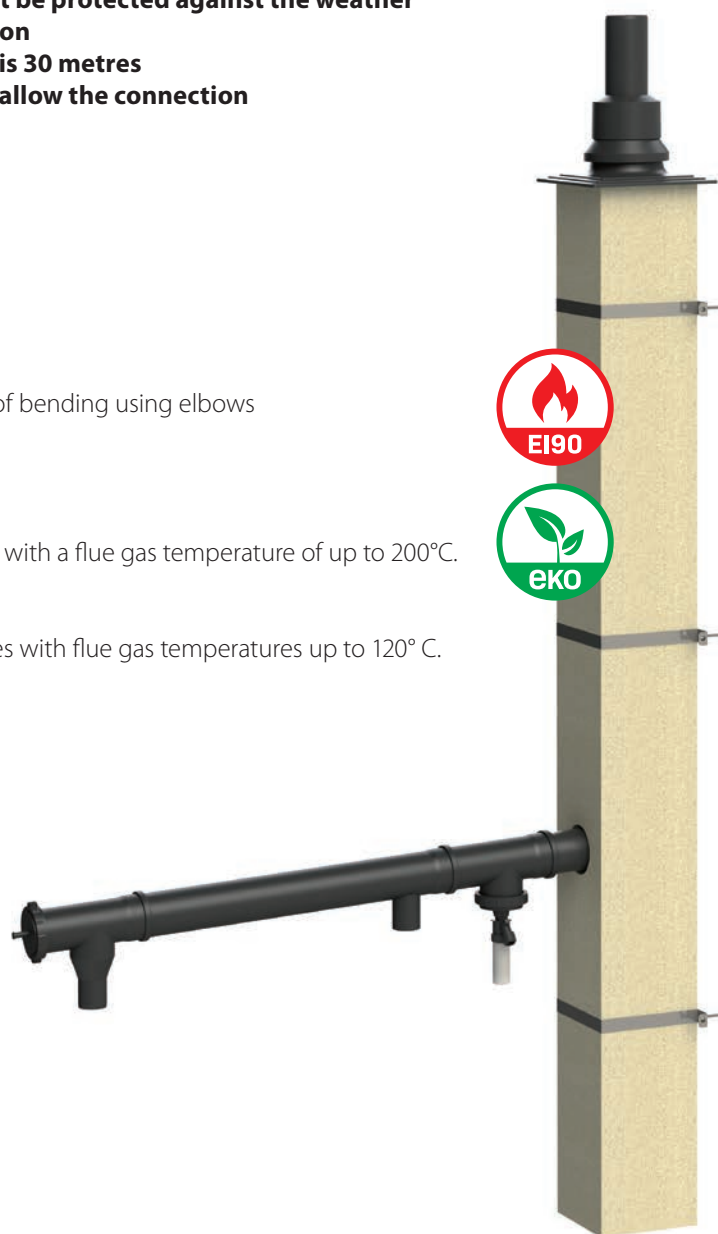
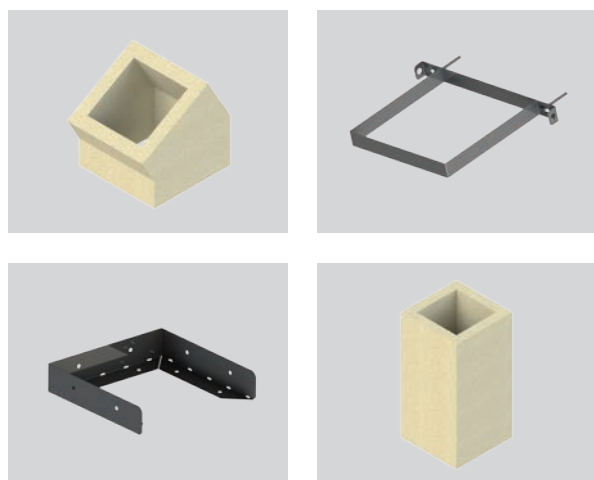

CHIMNEY PENETRATIONS THROUGH COMBUSTIBLE CONSTRUCTION



The chimney grommets and shafts under the KAMINSICHER label represent a system solution for fire-safety sections and penetrations through combustible structures. They serve as a safe insulation against combustible structures, reduce heat loss and limit unwanted heat gains through the wall, ceiling or roof. KAMINSICHER elements form a complete system that allows individual solutions for a specific building and any chimney.

ADVANTAGES

It is not an additional insulation

KAMINSICHER elements address the comprehensive safe and functional integration of the chimney into buildings, especially timber buildings and energy-efficient buildings. It is therefore not just an additional insulation for the connection of a vapour barrier membrane. It is a fire-safety, insulating element that also addresses other requirements for today's modern buildings.

The characteristics/classification of the chimney do not change

The chimney only passes through the shaft or grommet, so there is no need to change its classification, which would be necessary if an additional layer of chimney (additional insulation) were added. The chimney still has a declared safe distance from combustible structures of Gxx. The use of KAMINSICHER elements will result in the definition of this prescribed safe distance.

Reduction of temperatures in insulated structures

Fire tests have repeatedly confirmed the non-negligible effect of a unilaterally closed air gap between the chimney cladding and the chimney grommet. This air gap significantly reduces the temperatures in insulated structures while maintaining the pressure tightness.

Fixation to the building, not to the chimney

All KAMINSICHER components are always fixed to the supporting building structure, not to the chimney. Compared to additional insulations that are glued to the chimney, there is no problematic load-bearing joint that can be damaged over time when using KAMINSICHER components.

A proven product

The KAMINSICHER system has been used on the Czech market since 2015. In cooperation with leading suppliers of wooden buildings and energy-efficient houses, it has already been tested on hundreds of projects.

In 2017 and 2020 the product passed the test trials and measurements in the fire laboratory of the CTU UCEEB.



CHIMNEY BRIDGES

The chimney bridges make it easier to move around and work on the roof. The chimney ladder is not only needed by chimney sweeps or roofers, it can be used for any movement on the roof. It increases safety and makes access to the roof area easier. Whether it's for roof renovation, installation work, chimney sealing, regular inspection and maintenance or antenna installation, you'll reduce the risk of an accident with chimney bridges.

COLOR DESIGN

Chimney bridges are available in five colour variants according to the RAL colour chart:

- > zinc
- > RAL 8004 brick
- > RAL 3004 cherry
- > RAL 8012 brown
- > RAL 7016 anthracite
- > RAL 9005 black

Other RAL colours can be supplied on request.

CERTIFICATION

Certified by TZÚS Ostrava, in accordance with national standards, e.g.: CZ - ČSN 734201 Chimneys and flues - Art. 6.7.5 Chimney bridge, SK - STN 734201 Reconstructions and repairs of chimneys and flues. Common provisions - Art. 6.5 Chimney bridge.



zinc



RAL 8004
brick



RAL 3004
cherry



RAL 8012
brown



RAL 7016
anthracite

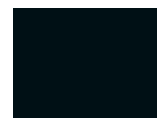

RAL 9005
black

SAUNA STOVE VILPRA

In cooperation with Vilpra, we have expanded our product range to include sauna stoves. Sauna stoves generally serve for heating saunas or can be used to heat water in a storage tank. It is advisable to use a three-layer DW flue gas extraction system with the stove.

Sauna stove Vilpra

A new brand in the world of saunas. By combining experience in combustion appliances with Finnish experience in sauna stoves, a Finnish-designed stove has been created that is characterised by high efficiency and durability.

Solid fuel stove for whirlpools

The stove was designed in collaboration with one of our Scandinavian partners. The external heater for the hottub is made of made of stainless steel. The use of this type of heater frees up space in the bathtub and reduces the risk of skin injury from burns.

Water heating capacity

The water heating tank is installed as a chimney element. It has a capacity of 24 litres and is made of stainless steel.

DW50M SAUNA double wall chimney system

The system is designed to extract combustion fumes by natural draft from sauna stoves. The chimney system for specific cases must be selected according to the documentation of the heating equipment manufacturer, the chimney installation instructions and national legislation.



COMPUTER PROGRAM KESA-ALADIN



The kesa-aladin calculation program is a software for professional chimney calculation according to EN 13384. With kesa-aladin, you can calculate a three-layer domestic chimney for an oil boiler as easily as a complex boiler house with five condensing boilers in a cascade.

We are a partner of the German company KESA, which develops and distributes the kesa-aladin software.

The kesa-aladin program is constantly evolving as standards and regulations change. In addition, new appliances, flue gas extraction systems or other components for fume extraction systems are coming onto the market and their characteristic data are constantly being added to the program.

As part of the maintenance of the software, you can always download the information and the new version from the website www.kesa.de, including the current characteristic data (appliances, smoke extraction systems, draught excluders, silencers, fume extraction systems, etc.) or update the characteristic data and information in the program using the built-in LiveUpdate function.

WE OFFER 2 VERSIONS OF KESA-ALADIN:

Standard

contains a tool for calculating the flue gas path of up to nine appliances connected in a cascade or in a common collector and up to ten appliances in a common chimney. In this version, a module for combustion air calculation can also be ordered.

Professional

contains a tool for calculating the flue gas path of up to nine appliances in cascade or in a common collector and up to twenty appliances in a common chimney. The program is graphically very clear and is easy, fast and

pleasant to work with. You can choose from several world languages in which to run the software. The program allows you to optimize the chimney flue or calculate the pressure and temperature ratios in all available diameters. Currently, our company together with the manufacturers of boilers, stoves and chimney systems is trying to ensure that the software contains up-to-date data of products from the Czech and Slovak Republic.

Once you purchase the full Czech version, you will receive license data from us, which will „unlock“ the full version of the software including the announced Czech language.



We didn't develop a new chimney, we improved it

TECHNICAL DEVELOPMENT PRODUCTS

ALMEVA EAST EUROPE a.s. cooperates closely with research institutions and education centres at all levels. We assign tasks and sponsor competitions for students of secondary vocational schools and apprenticeships, and we are partners for the practice of students of technical universities.

In cooperation with the Faculty of Civil Engineering of Brno University of Technology, we are testing a device for optimizing the energy balance of buildings, which we expect to use mainly on the Swiss market.

We are introducing to the Czech market new products designed and developed by a Swiss manufacturer ALMEVA AG and participate in their testing.

We continue to file utility and industrial design applications and patents for our selected products for the entire Group ALMEVA.

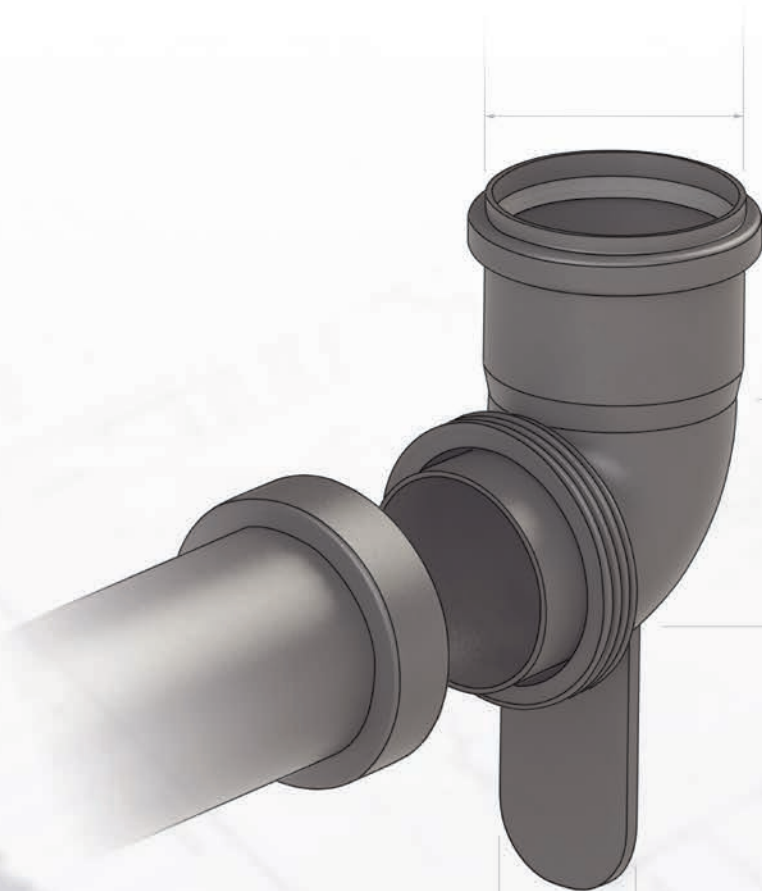

NEUTRALIZATION BOX ALMEVA

The ALMEVA neutralization box is designed to convert (neutralize) acid condensate from condensing boilers into neutral condensate.

CHARACTERISTICS

- › designed for condensing appliances and flue gas ducts where there is a risk of condensate formation

BENEFITS

- › three box sizes according to the power of the appliance: 120 kW, 350 kW, 1500 kW
- › easy handling and exchange of contents/stones
- › easy installation into operation, can be wall-mounted

The basic function of the box is to neutralize any acid condensate that is produced during the operation of condensing boilers. The condensate itself would flow out into the surrounding environment or wastewater. The negative impact of condensate on the environment is prevented by the neutralisation box from Almeva. The Almeva neutralisation box contains a special aggregate that converts acidic condensate into alkaline condensate and thus neutralises it.



INNOVATIVE SIPHON ALMEVA ZEUS

At Almeva, our motto is that we are constantly innovating and improving our chimney systems. We are a leader in the field of plastic flue systems and holds a number of patents. We present the new patented Zeus siphon, which we have developed in collaboration with our colleagues from the Greek branch of ALMEVA Hellas, based in Athens. To highlight the origin of its development and to show our appreciation to our colleagues, we have named it „Zeus“.

CHARACTERISTICS

- › the siphon is designed for single appliances as well as for flue gas paths with multiple appliances with a maximum output of 3 MW
- › possibility to connect a condensate level sensor to control systems - 5V DC voltage

ADVANTAGES

- › designed for all flue gas pressure classes P1, M1 and H1
- › possibility to install a condensate level sensor
- › The siphon is equipped with a Teflon ball, which prevents the flue gas from escaping into the surroundings even if there is no liquid in the working part

Main functions of the siphon in the flue gas path

The siphon serves to drain the condensate and at the same time prevents the flue gas from escaping into the surroundings and avoids the risk of poisoning by combustion products. It acts as an imaginary stopper, separating the flue from the outside environment.

Location of the siphon

In single appliance installations, the siphon is most often located in the appliance. The condensate generated in the flue gas path is led back to the appliance, where it is discharged through the condensate exchanger and the integrated siphon into the waste pipe. In cascade systems this solution is not possible because the boilers are sized for the amount of condensate discharged per appliance. If condensate flows from multiple appliances, this could cause overflow and damage to the equipment itself. In cascade systems, the siphon is therefore always placed on the flue pipe itself.



87° KNEE FOR INSERTION

The easy insertion elbow is used for simple and quick insertion of an existing chimney, for example when changing the boiler (from an atmospheric gas boiler to a condensing boiler).

The biggest problem in the rehabilitation of chimney bodies is the detail of the chimney foundation, where we cannot do without structural modifications around the connection. Thanks to the geometry of the elbow, this work is completely eliminated and it is not necessary to intervene in the existing roof.

When the chimney is inserted, the elbow is lowered together with a flexi hose or pipe through the entire chimney shaft to the point of connection, and then the horizontal section is screwed in and anchored over the existing flue. In this way, the chimney is up and running in a few moments, without unnecessary demolition and subsequent modifications.

There is also an easy-insertion reduced elbow, which is also used for inserting the chimney shaft and also has a reduction already integrated in it.

The Guild of Heating Engineers and Plumbers of the Czech Republic has awarded ALMEVA EAST EUROPE a.s. Certificate of Quality Guaranteed by the CTI of the Czech Republic, for the product Elbow 87° for insertion of reduced DN 80/60, manufacturer's designation PBEB58. The Association of Chimney Sweepers of the Czech Republic, represented by the Chamber of Commerce of the Czech Republic, assessed the expertise and quality of the entire company ALMEVA EAST EUROPE a.s. and issued the company with a Certificate of Quality.



SOFTWARE FROM ALMEVA FOR CHIMNEY CALCULATION

ALMECON

On the basis of many years of experience, our company has developed the ALMECON calculation program, which enables the creation of a line item budget based on the selection of individual system elements.

The calculation program allows you to select any chimney system from the menu in the website environment. To select a chimney system or its parts, select individual parameters from the selection, which allows you to easily build a chimney according to the required technical parameters.

In the calculation program, the chimney can also be assembled from individual items. By entering the catalogue number given in our price lists and catalogues, additional items can easily be added. Items can be transferred to the quotation for price calculation and then ordered.

To verify the functionality of the configured flue according to EN 13384 - 1, 2, please contact us.

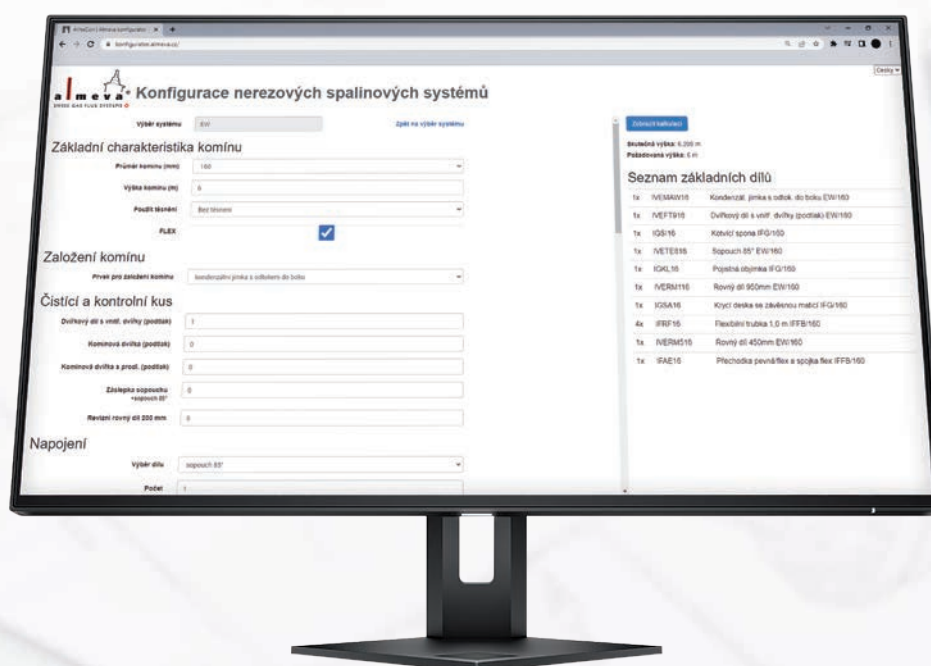



Leave the chimney at Almeva...



Most items in stock

As a manufacturer of chimney systems, we have warehouses where all the range we currently offer is represented. We strive to maintain stock levels such that customers always take away the following, what they need for implementation.



Flue gas calculation

We are a partner of the German company KESA, which develops and distributes the kesa-aladin. The program enables professional chimney calculation according to EN 13384. Whether you need to calculate a three-layered domestic chimney or a cascade connection for multiple condensing boilers, it will always be quick and easy using our software. The software responds to changes in standards and the market as new appliances are developed. We provide free calculations to our partners.



Chimney configurator

Do you have an idea of what the chimney you need for your customer might look like, and do you need to assemble its form from the elements and parts it must contain? Our chimney configurator will help you to do this, as it is used to quickly assemble all the necessary elements of a given system. You are able to offer the assembly immediately with a price calculation. This gives you a head start on the competition and gives you time to devote to the job or the customer.



Training of professionals

We offer comprehensive training to industry professionals to help them become more familiar with changes in legislation, new developments and products on the market. Training is always at the beginning of the year and focuses on Almeva flue systems, kesa-aladin software and Exodraft products. The training will give you the confidence to work and install flue systems and you will learn a lot of hints, tips and tricks on how to work with different types of systems and materials.



Services for partners

We offer a wide range of services for partners from contractors, wholesalers, design offices or boiler manufacturers and suppliers.

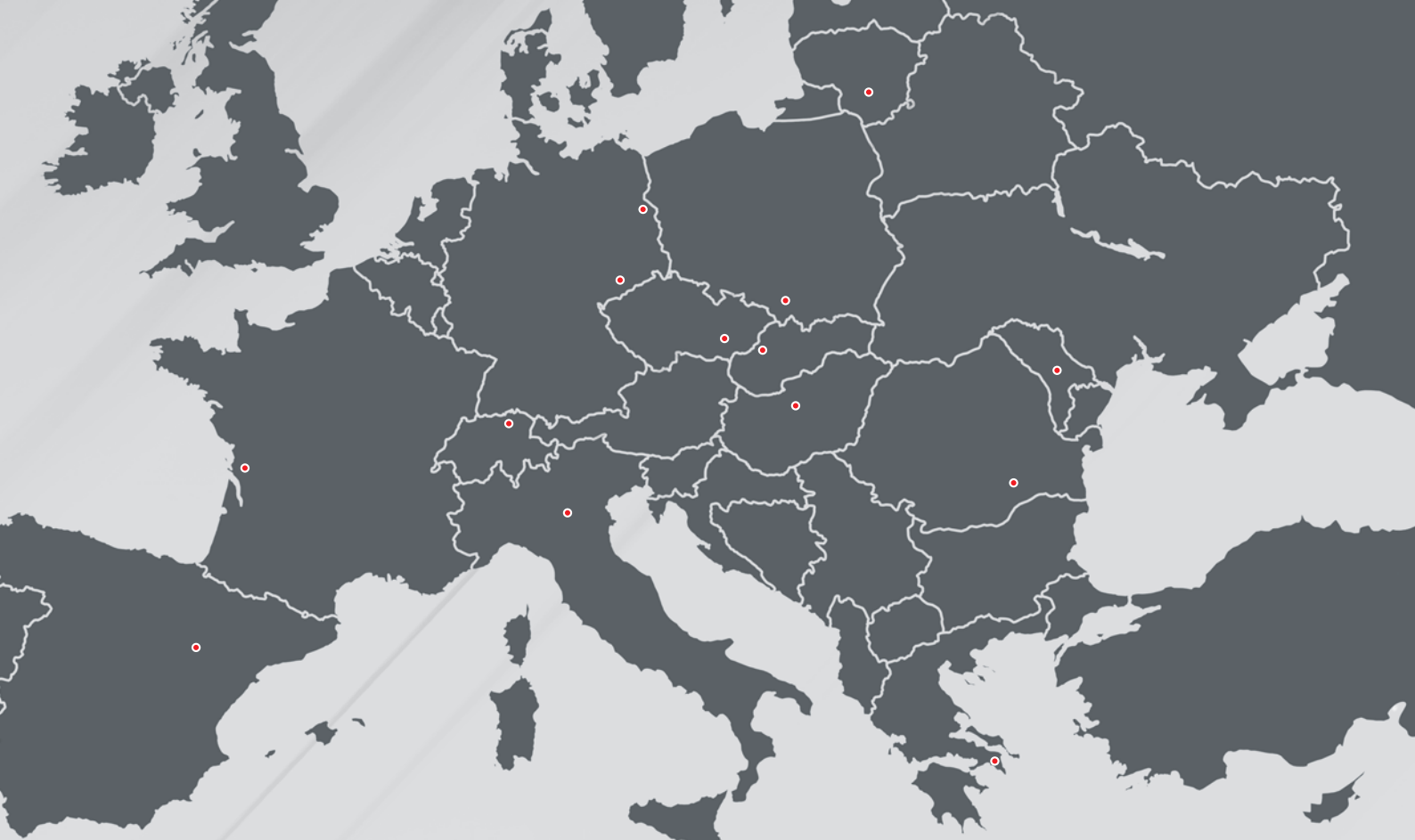

almeva AG
 Industriestrasse 6
 CH-9220 Bischofszell
 Switzerland
 Tel.: +41 71 644 90 20
 E-mail: info@almeva.ch



almeva SAS
 Parc d'Activité Les Pierailleuses
 F-79360 Granzay-Gript
 France
 Tel.: +33 613 022 075
 E-mail: fr@almeva.eu



ALMEVA EAST EUROPE a.s.
 Družstevní 501
 CZ-664 43 Želešice u Brna
 Czech Republic
 Tel.: +420 513 033 101
 E-mail: cz@almeva.eu



ALMEVA POLAND Sp. z o.o.
 ul. Cieszyńska 2,
 PL-43-200 Pszczyna
 Poland
 Tel.: +48 32 475 71 04
 E-mail: pl@almeva.eu



almeva Deutschland GmbH
 Gewerbegebiet 7
 D-09306 Königshain-Wiederau
 Germany
 Tel.: +49 37 20 28 59 24 0
 E-mail: verkauf@almeva.com



SEG ALMEVA Ibérica SL
 Parque Empresarial de Utebo
 Avda. Miguel Servet S/M, Nave 14
 E-50180 Utebo – Zaragoza, Spain
 Tel.: +34 647 911 328
 E-mail: es@almeva.eu



ALMEVA SLOVAKIA s.r.o.
 Bratislavská 119
 SK-911 05 Trenčín
 Slovakia
 Tel.: +421 322 028 946
 E-mail: sk@almeva.eu



ALMEVA HUNGARY Kft.
 Szentmihályi út 167–169 (office F2.14.D03)
 H-1152 Budapest
 Hungary
 Tel.: +36 13 009 012
 E-mail: hu@almeva.eu



almeva Metalltechnik GmbH
 Fürstenwalder Str. 57
 D-15859 Storkow (Mark)
 Germany
 Tel.: +49 33 67 84 33 40
 E-mail: verkauf@almeva.com



almeva Italia s.r.l.
 Viale del lavoro 7
 I-37069 Villafranca di Verona
 Italy
 Tel.: +390 456 391 399
 E-mail: info@almevaitalia.it



almeva in the Baltic countries
 by ALMEVA EAST EUROPE a.s.
 Lithuania Tel.: +370 700 660 41
 Latvia Tel.: +371 67 660 689
 Estonia Tel.: +372 63 463 93
 E-mail: baltic@almeva.eu



Almeva in Greece
 Α. Φιλαδέλφειας 342
 GR-13671 Αχαρνάι, Αθήνα
 Ελλάδα
 Τηλ.: +30 210 2322970
 E-mail: info@almeva.gr



almeva in Romania and Moldavia
 by ALMEVA EAST EUROPE a.s.
 Romania Tel.: +40 31 229 60 88
 E-mail: ro@almeva.eu
 Moldavia Tel.: +373 692 355 25
 E-mail: md@almeva.eu



almeva US LLC/Solarion LLC
 1074 Hope Street
 CT 06907 Stamford
 United States
 Cell: +1 203 524 7018
 E-mail: solarion@gmail.com

